

BC04 Class 1 Bluetooth Module

Data Sheet

DESCRIPTION

The BC04 Class1 Bluetooth Module is a Class 1 Bluetooth module using BlueCore4-External chipset from leading Bluetooth chipset supplier, Cambridge Silicon Radio. It provides a fully compliant Bluetooth system for data and voice communications. Interfaces with a host via USB or UART and support full data rate up to 3Mbps modulation modes. Voice interface supported PCM protocol. The module and device firmware is fully compliant with the Bluetooth specification v2.0. Its sufficient pin definitions, high receiving sensitivity, low power consumption, and low cost, BC04 Class1 Bluetooth Module is suitable for need long distance transmission devices.



Features

- Operating Frequency Band 2.40 GHz ~ 2.48GHz unlicensed ISM Band
- Bluetooth Spec. v2.0 Compliant + EDR
- Enhanced Data Rate (EDR) compliant with v2.0.E.2 of specification for both 2Mbps and 3Mbps modulation modes
- Class 1 type Output Power
- Support Firmware Upgrade
- Support Piconet, up to 7 Slaves
- Scatternet Support
- USB 2.0 and UART Host Interface
- PCM Audio Interface
- Low Voltage Power Supply, 2.7V to 3.6V
- Nominal Supply Voltage at 3.3±0.1V
- Built-in 8Mbit Flash Memory
- Low Power Modes Available: Park, Sniff, Hold and Deep Sleep
- Surface-mount, Size: 27.5 x 14.5 x 2 mm

Applications

- PCs, PDAs
- Computer Accessories (CF Cards, USB Dongles, PCMCIA, RS232 Adaptors, etc.)
- Mice, Keyboard, Joysticks
- Cordless Phone
- FAX, Printer Adaptors
- Digital Camera
- Access Points to LAN and/or Dial-up network

Block Diagram

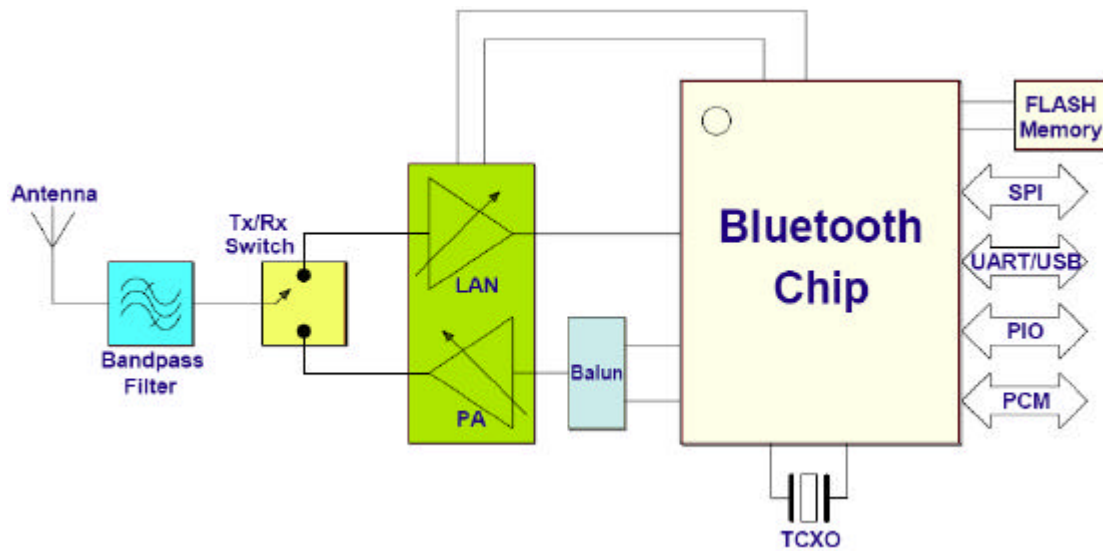

The transmitter design consists of a Bluetooth Chip device connected to an Atmel power amplifier via a matching network and balun. Harmonic filtering, a transmit/receive switch, a ceramic bandpass filter and a SMA connector are also included.

The receiver uses the same antenna, bandpass filter and transmit/receive switch as the transmitter. To improve the sensitivity, the LNA within the Atmel device and the single-ended receiver port of Bluetooth Chip are used.

Pin Descriptions

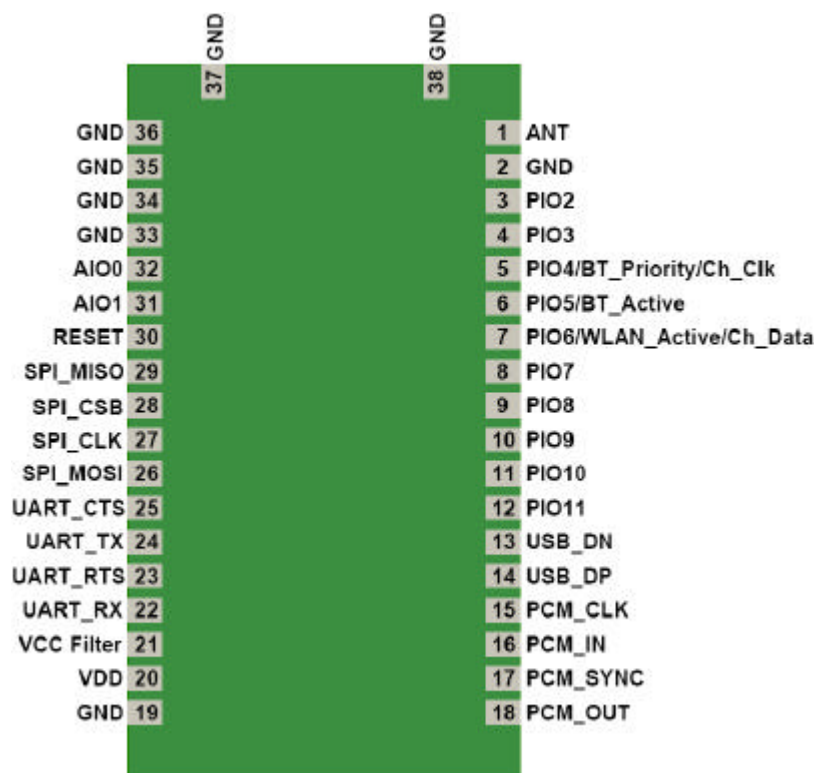

PIN	NAME	TYPE	DESCRIPTION
1	ANT	I/O	Transmitter out and receiver input
2	GND	GND	Ground
3	PIO2	Bi-directional with programmable strength internal pull-up/down	Programmable Input/Output Line
4	PIO3	Bi-directional with programmable strength internal pull-up/down	Programmable Input/Output Line
5	PIO[4]/ BT_Priority/ Ch_Clk	Bi-directional with programmable strength internal pull-up/down	Programmable input/output line or Optionally BT_Priority/Ch_Clk output for co-existence signalling
6	PIO[5]/ BT_Active	Bi-directional with programmable strength internal pull-up/down	Programmable input/output line or Optionally BT_Active output for co-existence signalling
7	PIO[6]/ WLAN_Active/ Ch_Data	Bi-directional with programmable strength internal pull-up/down	Programmable input/output line or Optionally WLAN_Active/Ch_Data input for co-existence signalling
8	PIO7	Bi-directional with programmable strength internal pull-up/down	Programmable Input/Output Line
9	PIO8	Bi-directional with programmable strength internal pull-up/down	Programmable Input/Output Line

10	PIO9	Bi-directional with programmable strength internal pull-up/down	Programmable Input/Output Line
11	PIO10	Bi-directional with programmable strength internal pull-up/down	Programmable Input/Output Line
12	PIO11	Bi-directional with programmable strength internal pull-up/down	Programmable Input/Output Line
13	USB_DN	Bi-directional	USB Data-
14	USB_DP	Bi-directional	USB Data+
15	PCM_CLK	Bi-directional with weak internal pull-down	Synchronous Data Clock
16	PCM_IN	CMOS input, with weak internal pull-down	Synchronous 8kss data out
17	PCM_SYNC	Bi-directional with weak internal pull-down	Synchronous Data Strobe
18	PCM_OUT	CMOS output, tri-state, with weak internal pull-down	Synchronous Data Output
19	GND	GND	Ground
20	VDD	Power Supply	3V3 for RF circuit
21	VCC Filter		Filter Capacitor for 1.8V
22	UART_RX	CMOS input with weak internal pull-down	Asynchronous Serial Data
23	UART_RTS	CMOS output, tri-state, with weak internal pull-up	UART ready to send
24	UART_TX	CMOS output, tri-state, with weak internal pull-up	Asynchronous Serial Data Output
25	UART_CTS	CMOS input with weak internal pull-down	UART clear to send
26	SPI_MOSI	CMOS input with weak internal pull-down	Synchronous Serial Interface Data Input
27	SPI_CLK	CMOS input with weak internal pull-down	Synchronous Serial Interface Clock
28	SPI_CSB	CMOS input with weak internal pull-up	Chip select for Synchronous Serial Interface
29	SPI_MISO	CMOS output, tri-state, with weak internal pull-down	Synchronous Serial Interface Data Input
30	RESET	CMOS input with weak internal pull-up	internal pull-up Reset if low. Input debounced so must be low for >5ms to cause a reset
31	AIO1	Bi-directional	Programmable Input/Output line
32	AIO0	Bi-directional	Programmable Input/Output line
33	GND	GND	Ground
34	GND	GND	Ground
35	GND	GND	Ground
36	GND	GND	Ground

37	GND	GND	Ground
38	GND	GND	Ground

Electrical Specifications

Electrical Characteristics

Input/Output Terminal Characteristics

Digital Terminals	Min	Typ	Max	Unit
Input Voltage Levels				
VIL input logic level low 2.7V = VDD = 3.0V	-0.4	-	+0.8	V
VIH input logic level high	0.7VDD	-	VDD+0.4	V
Output Voltage Levels				
VOL output logic level low (Io = 4.0mA), 2.7V = VDD = 3.0V	-	-	0.2	V
VOH output logic level high (Io = -4.0mA), 2.7V = VDD = 3.0V	VDD-0.2	-	-	V
Input and Tri-state Current with				
Strong pull-up	-100	-40	-10	μA
Strong pull-down	+10	+40	+100	μA
Weak pull-up	-5.0	-1.0	-0.2	μA
Weak pull-down	+0.2	+1.0	+5.0	μA
I/O pad leakage current	-1	0	+1	μA
CI Input Capacitance	1.0	-	5.0	pF

Input/Output Terminal Characteristics(Continued)

USB Terminals	Min	Typ	Max	Unit
VDD_USB for correct USB operation (1)	3.1	-	3.6	V
Input threshold				
VIL input logic level low	-	-	0.3VDD_USB	V
VIH input logic level high	0.7VDD_USB	-	-	V
Input leakage current				
VSS_PADS < VIN < VDD_USB(1)	-1	1	5	μA
CI Input capacitance	2.5	-	10.0	pF
Output Voltage levels To correctly terminated USB Cable				
VOL output logic level low	0.0	-	0.2	V
VOH output logic level high	2.8	-	VDD_USB	V

Absolute Maximum ratings

Absolute maximum ratings for supply voltage and voltages on digital and analogue pins of the Module are listed below; exceeding these values will cause permanent damage.

Parameter	Min	Max	Unit
Peak current of power supply	0	75	mA
Voltage at digital pins	-0.3	3.6	V
Voltage at POWER pin	2.7	3.6	V

Radio Characteristica:Basic Data Rate

The Example Design based on BlueCore4-External and the Atmel PA/LNA meets the Bluetooth specification v2.0 + EDR when used between -20° C and +65° C.

Transmitter					
Radio Characteristics VDD=3.15V Temperature=+20°C					
Min	Typ	Max	Bluetooth Specification	Unit	
Maximum RF transmit power	-	14 ⁽³⁾	-	0 to +20 ⁽⁴⁾	dBm
Variation in RF power over temperature range with compensation disabled (±)	-	2.0	-	-	dB
Variation in RF power over temperature range with compensation enabled (±)	-	1.0	-	-	dB
RF power control range	-	>20	-	16	dB
RF power range control resolution	-	0.5	-	-	dB
20dB bandwidth for modulated carrier	-	670	-	1000	kHz
Adjacent channel transmit power $F=F_0 \pm 2\text{MHz}$	-	-35	-	-20	dBm
Adjacent channel transmit power $F=F_0 \pm 3\text{MHz}$	-	-40	-	-40	dBm
Adjacent channel transmit power $F=F_0 > \pm 3\text{MHz}$	-	-47	-	-40	dBm
f1avg Maximum Modulation	-	159	-	$140 < f_{1\text{avg}} < 175$	kHz
f2max Minimum Modulation	-	123	-	115	kHz
f2avg / ?f1avg	-	0.84	-	0.80	-
Initial carrier frequency tolerance	-	6.0	-	± 75	kHz
Drift Rate	-	8.0	-	20	kHz/50µs
Drift (single slot packet)	-	9.0	-	25	kHz
Drift (five slot packet)	-	11.0	-	40	kHz
2 nd Harmonic content	-	-43	-	- 30	dBm
3 rd Harmonic content	-	-34	-	- 30	dBm

Notes:

- (1) The design is capable of producing 18dBm at 20°C. However, in order to meet both the FCC Part 15.205a and 15.209a radiated spurious requirement of -41dBm/MHz (500microvolts/metre at a distance of 3 metres) and the Bluetooth requirement for ACP, it is necessary to limit the maximum output power to +14dBm at 20°C. The corresponding recommended POWER_TABLE entry is internal gain 55, external gain 170.
- (2) Class 1 RF transmit power range, Bluetooth specification v2.0 + EDR.
- (3) To some extent these parameters are dependent on the matching circuit used and its behaviour over temperature. Therefore, these parameters may be beyond CSR's direct control.
- (4) Resolution guaranteed over the range -5dB to -25dB relative to maximum power for Tx Level >20.
- (5) Measured at $F_0 = 2441\text{MHz}$.

English web: www.OEMblue.com

Chinese web: www.jinoux.com

- (6) Up to three exceptions are allowed in v2.0 + EDR of the Bluetooth specification. BlueCore4-External is guaranteed to meet the ACP performance as specified by the Bluetooth specification v2.0 + EDR.
- (7) Measurement made using a POWER_TABLE entry of internal gain 55, external gain 170. This ensures that the Bluetooth requirements and those defined by the FCC and ETSI are satisfied over the operating temperature range of -20°C to +65°C. Measured using an operating output power of 14dBm at 20°C.

Receiver						
Radio Characteristics VDD = 3.15V Temperature = +20°C						
Frequency (GHz)	Min	Typ	Max		Bluetooth Specification	Unit
Sensitivity at 0.1% BER for all packet types	2.402	-	-86.5	-	-70	dBm
2.441	-	-86.5	-	-		
2.480	-	-87.0	-	-		
Maximum received signal at 0.1% BER		-	>-20	-	-20	dBm
Frequency (MHz)	Min	Typ	Max		Bluetooth Specification	Unit
Continuous power required to block Bluetooth reception (for sensitivity of -67dBm with 0.1% BER). Measured at the antenna connection.	30 – 2000	-	>0	-	-10	dBm
	2000 – 2400	-	>-15	-	-27	
	2500 – 3000	-	>-18	-	-27	
C/I co-channel		-	9	-	11	dB
Adjacent channel selectivity C/I $F=F_0+1\text{MHz}$		-	-4	-	0	dB
Adjacent channel selectivity C/I $F=F_0-1\text{MHz}$		-	-2	-	0	dB
Adjacent channel selectivity C/I $F=F_0+2\text{MHz}$		-	-38	-	-30	dB
Adjacent channel selectivity C/I $F=F_0-2\text{MHz}$		-	-21	-	-20	dB
Adjacent channel selectivity C/I $F=F_0\mp 3\text{MHz}$		-	-43	-	-40	dB
Adjacent channel selectivity C/I $F=F_0-5\text{MHz}$		-	-43	-	-40	dB
Adjacent channel selectivity C/I $F=F_{\text{Image}}$		-	-21	-	-9	dB
Maximum level of intermodulation interferers		-	-37	-	-39	dBm
Spurious output level		-	-140	-	-	dBm/Hz

Notes:

- (1) Up to five exceptions are allowed in v2.0 + EDR of the Bluetooth specification. BlueCore4-External is guaranteed to meet the C/I performance as specified by the Bluetooth specification v2.0 + EDR
- (2) Measured at $F_0 = 2441\text{MHz}$
- (3) Measured at $f1-f2 = 5\text{MHz}$. Measurement is performed in accordance with Bluetooth RF test RCV/CA/05/c, i.e. wanted signal at -64dBm
- (4) Measured at the antenna connection. Integrated in 100kHz bandwidth and then normalized to 1Hz. Bluetooth band of frequencies, with exceptions of -84dBm at 1625MHz, -76dBm at 2435MHz, and -68dBm at 3200MHz.

Radio Characteristics: Enhanced Data Rate

Transmitter							
Radio Characteristics VDD = 3.15V Temperature = +20°C							
Min	Typ	Max		Bluetooth Specification		Unit	
Maximum RF transmit power		-	18 ⁽²⁾	-	0 to +20 ⁽³⁾	dBm	
Relative transmit power		-	-2	-	-4 to +1	dB	
/4 DQPSK Max carrier frequency stability w_0		-	1.5	-	± 10 for all blocks	kHz	
/4 DQPSK Max carrier frequency stability w_i		-	6.6	-	± 75 for all packets	kHz	
/4 DQPSK Max carrier frequency stability $ w_0 + w_i $		-	7.0	-	± 75 for all blocks	kHz	
8DPSK Max carrier frequency stability w_0		-	1.5	-	± 10 for all blocks	kHz	
8DPSK Max carrier frequency stability w_i		-	4.5	-	± 75 for all packets	kHz	
8DPSK Max carrier frequency stability $ w_0 + w_i $		-	5.0	-	± 75 for all blocks	kHz	
/4 DQPSK Modulation Accuracy		RMS DEVM	-	7.0	-	20	%
		99% DEVM	-	12.0	-	30	%
		Peak DEVM	-	16.0	-	35	%
8DPSK Modulation Accuracy		RMS DEVM	-	8.0	-	13	%
		99% DEVM	-	13.0	-	20	%
		Peak DEVM	-	16.0	-	25	%
In-band spurious emissions		$F > F_0 + 3\text{MHz}$	-	-45	-	-40	dBm
		$F < F_0 - 3\text{MHz}$	-	-45	-	-40	dBm

	$F = F_0 - 3\text{MHz}^{(6)}$	-	-38	-	-40	dBm
	$F = F_0 - 2\text{MHz}$	-	-25	-	-20	dBm
	$F = F_0 - 1\text{MHz}$	-	-36	-	-26	dB
	$F = F_0 + 1\text{MHz}$	-	-36	-	-26	dB
	$F = F_0 + 2\text{MHz}$	-	-25	-	-20	dBm
	$F = F_0 + 3\text{MHz}^{(6)}$	-	-28	-	-40	dBm
EDR Differential Phase Encoding		-	No Errors	-	=99	%

Notes:

- (1) BlueCore4-External firmware maintains the transmit power to be within the Bluetooth v2.0 + EDR specification limits.
- (2) Although the design is capable of generating in excess of +18dBm, regulatory compliance over the full temperature range of -20°C to +65°C will not be satisfied if the transmit power approaches this value. Actual output power with TX_PRE 71, INT PA 63, EXT PA 255 corresponds to +8dBm at 20°C.
- (3) Class 1 RF transmit power range, Bluetooth v2.0 + EDR specification.
- (4) Measurements methods are in accordance with the EDR RF Test Specification v2.0.E.2.
- (5) Modulation accuracy utilises Differential Error Vector Magnitude (DEVm) with tracking of the carrier frequency drift.
- (6) The Bluetooth specification values are for 8DPSK modulation. Up to three exceptions are allowed in the Bluetooth v2.0 + EDR specification. BlueCore4-External is guaranteed to meet the ACP performance as specified by the Bluetooth v2.0 + EDR specification.

Receiver						
Radio Characteristics		VDD = 3.15V			Temperature = +20° C	
Modulation	Min	Typ	Max	Bluetooth Specification	Unit	
Sensitivity at 0.01% BER	/4 DQPSK	-	-89	-	-70	dBm
	8DPSK	-	-82	-	-70	dBm
Maximum received signal at 0.1% BER	/4 DQPSK	-	>0	-	-20	dBm
	8DPSK	-	-10	-	-20	dBm
C/I co-channel at 0.1% BER	/4 DQPSK	-	10	-	+13	dB
	8DPSK	-	18	-	+21	dB
Adjacent channel selectivity C/I $F=F_0+1\text{MHz}$	/4 DQPSK	-	-11	-	0	dB

	8DPSK	-	-5	-	+5	dB
Adjacent channel selectivity C/I F=F ₀ -1MHz	/4 DQPSK	-	-8	-	0	dB
	8DPSK	-	-4	-	+5	dB
Adjacent channel selectivity C/I F=F ₀ +2MHz	/4 DQPSK	-	-43	-	-30	dB
	8DPSK	-	-38	-	-25	dB
Adjacent channel selectivity C/I F=F ₀ -2MHz	/4 DQPSK	-	-22	-	-20	dB
	8DPSK	-	-22	-	-13	dB
Adjacent channel selectivity C/I F=F ₀ +3MHz	/4 DQPSK	-	-46	-	-40	dB
	8DPSK	-	-42	-	-33	dB
Adjacent channel selectivity C/I F=F ₀ -5MHz	/4 DQPSK	-	-43	-	-40	dB
	8DPSK	-	-40	-	-33	dB
Adjacent channel selectivity C/I F=F _{Image}	/4 DQPSK	-	-21	-	-7	dB
	8DPSK	-	-14	-	0	dB

Notes:

(1) Measured at F₀ = 2405MHz, 2441MHz, 2477MHz.

Typical Application Circuit

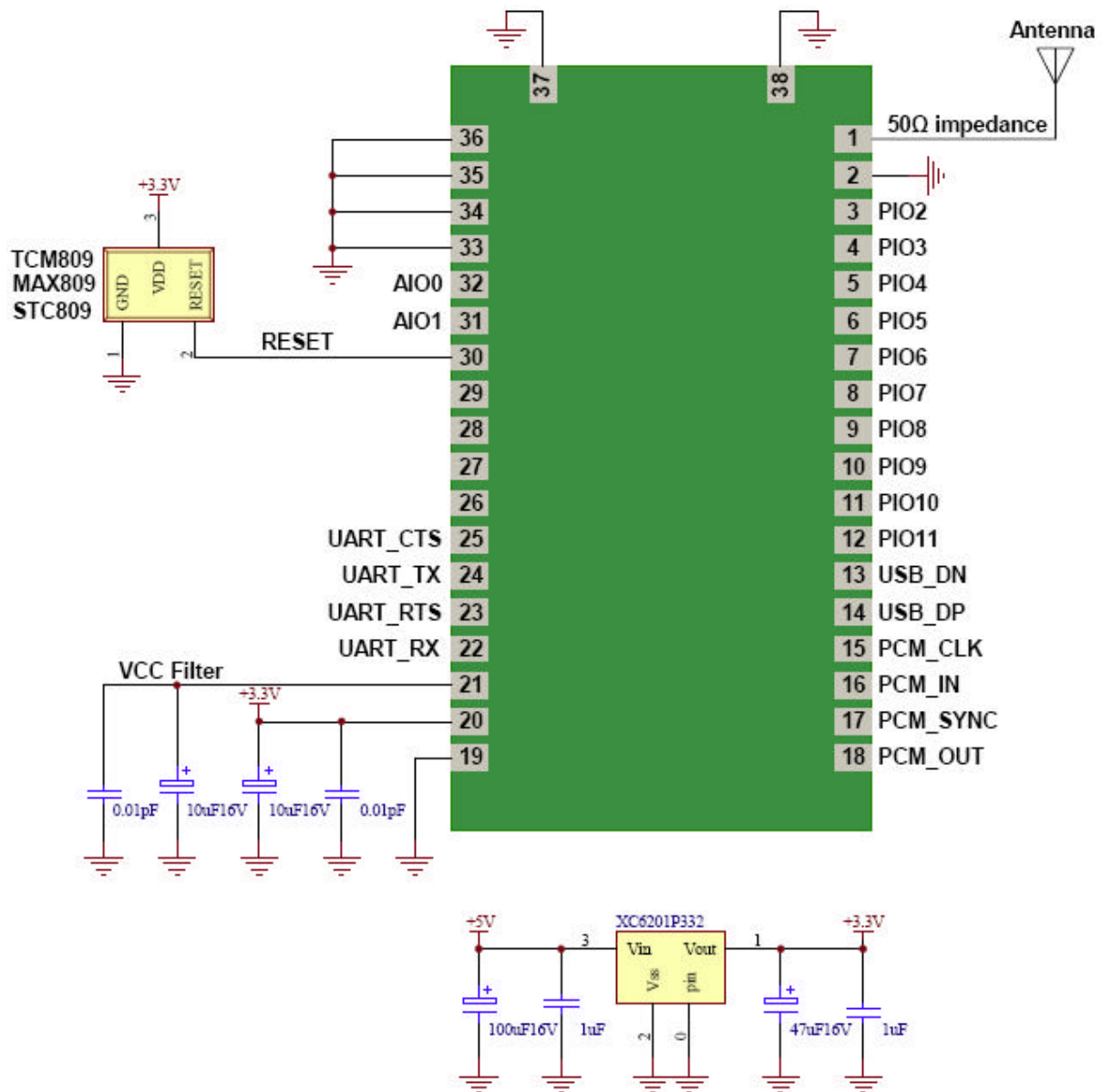

Schematic for a Typical Application Circuit

Physical Dimensions

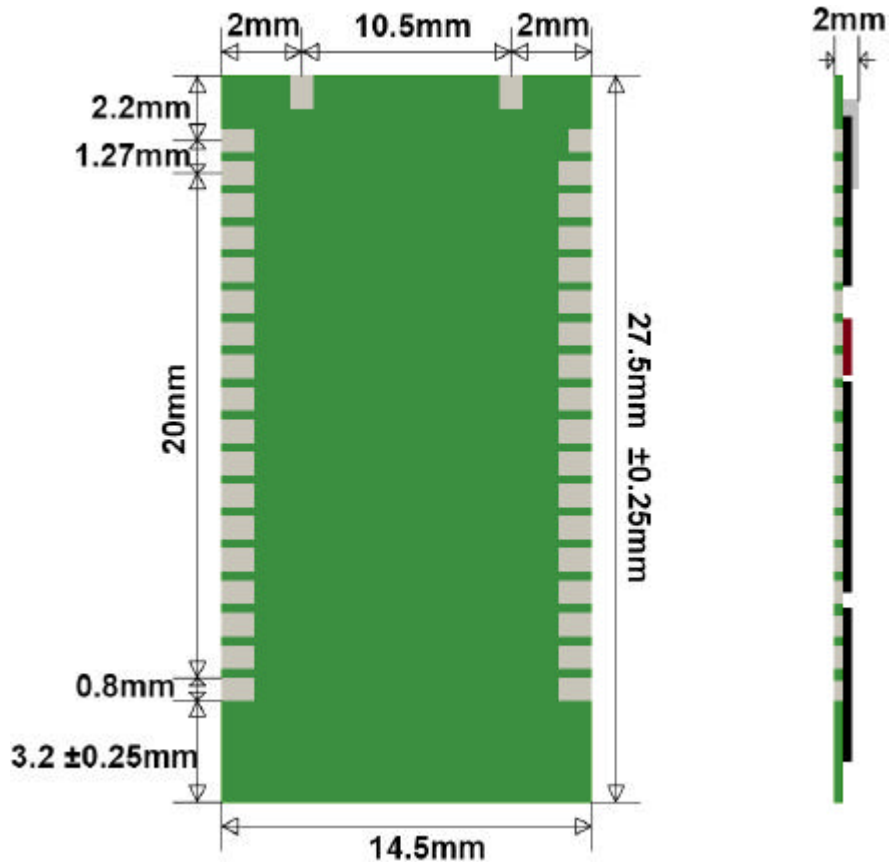

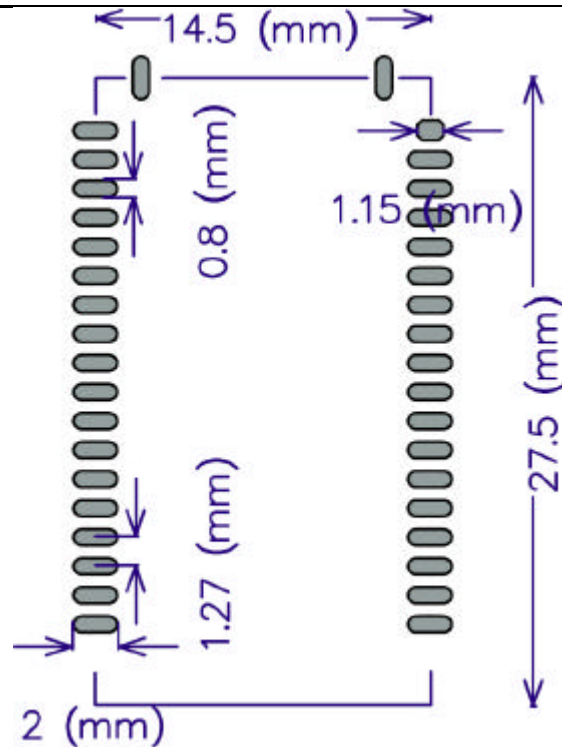

Recommended PCB Land Pattern Solder Profiles

The soldering profile depends on various parameters necessitating a set up for each application. The data here is given only for guidance on solder re-flow. There are four zones:

- 1.Preheat Zone - This zone raises the temperature at a controlled rate, typically 1-2.5°C/s.
- 2.Equilibrium Zone - This zone brings the board to a uniform temperature and also activates the flux.

The duration in this zone (typically 2-3 minutes) will need to be adjusted to optimise the out gassing of the flux.

3.Reflow Zone - The peak temperature should be high enough to achieve good wetting but not so high as to cause component discoloration or damage. Excessive soldering time can lead to intermetallic growth which can result in a brittle joint.

4.Cooling Zone - The cooling rate should be fast, to keep the solder grains small which will give a longer lasting joint. Typical rates will be 2-5°C/s.

Solder Re-Flow Profile

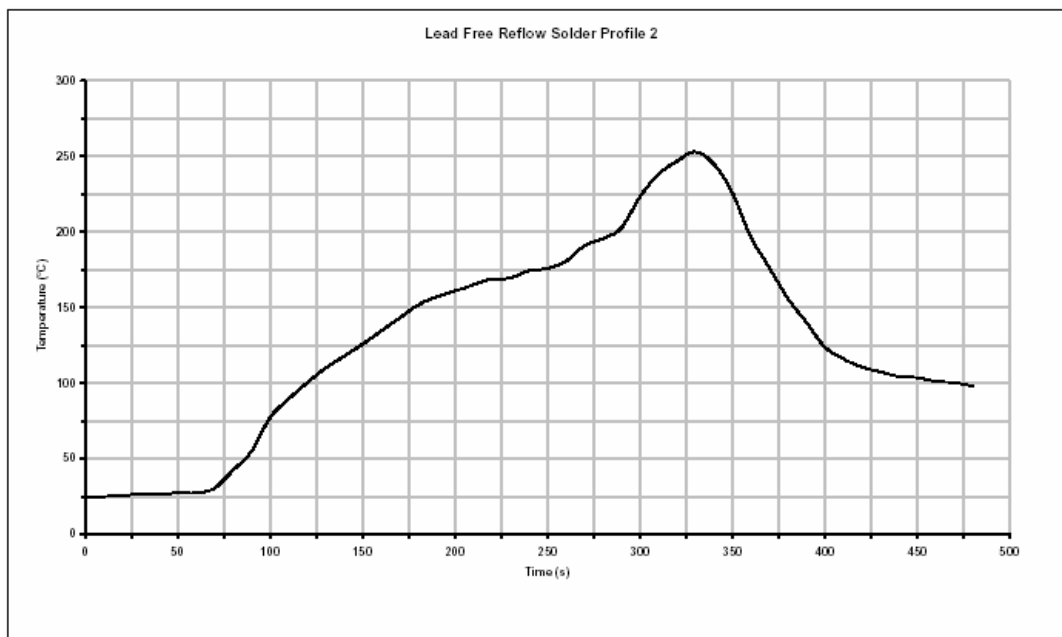

Typical Lead-Free Re-flow Solder Profile

Key features of the profile:

- Initial Ramp = 1-2.5°C/sec to 175° C±25° C equilibrium
- Equilibrium time = 60 to 180 seconds
- Ramp to Maximum temperature (250°C) = 3°C/sec max.
- Time above liquidus temperature (217° C): 45-90 seconds
- Device absolute maximum reflow temperature: 260°C

Devices will withstand the specified profile. Lead-free devices will withstand up to three reflows to a maximum temperature of 260°C.

Notes : They need to be baked prior to mounting.

Document References

Document	Reference
Approval Standards : European Telecommunications Standards Institute. Radio Equipment and Systems (RES); Wideband transmission systems; Technical characteristics and test conditions for data transmission equipment operating in the 2.4GHz ISM band and using spread spectrum techniques.	ETS 300 328
Federal Communications Commission (FCC) Radio Frequency Devices	FCC Part 15
Specification of the Bluetooth System, Core System Package	Volume 2 Part A Volume 3 Part D
Bluetooth Specification. Radio Specification. Core System Package Part A. Test Suite Structure (TSS) and Test Purposes (TP). System Specification 1.2/2.0/2.0 + EDR	Document Number RF.TS/2.0.E.2, Revision 2.0.E.2, Issued 4th November 2004

English web: www.OEMblue.com

Chinese web: www.jinoux.com



Chongqing JINO Science and Technology Development Co.,Ltd.

Address: GuiGu City Villa 12-2-101,Huaxuan Road 108# ,Hi-Tech
Development Zone,Chongqing, 400041,P.R.China

Postcode: 400041

English Web: www.OEMblue.com

Chinese Web: www.jinoux.com

Tel.: +86-23-68798999

Fax: +86-23-68889515
